

2

1

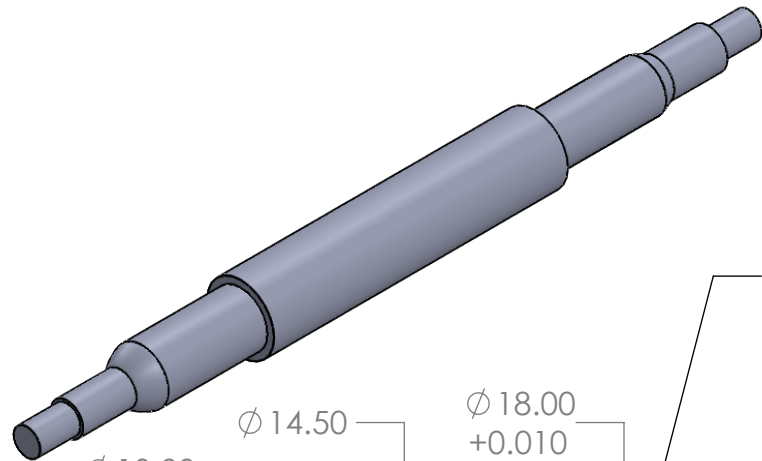

Fillet	Radius (mm)	Conic Rho
1	9.9	0.25
2	7.2	0.05

B

B

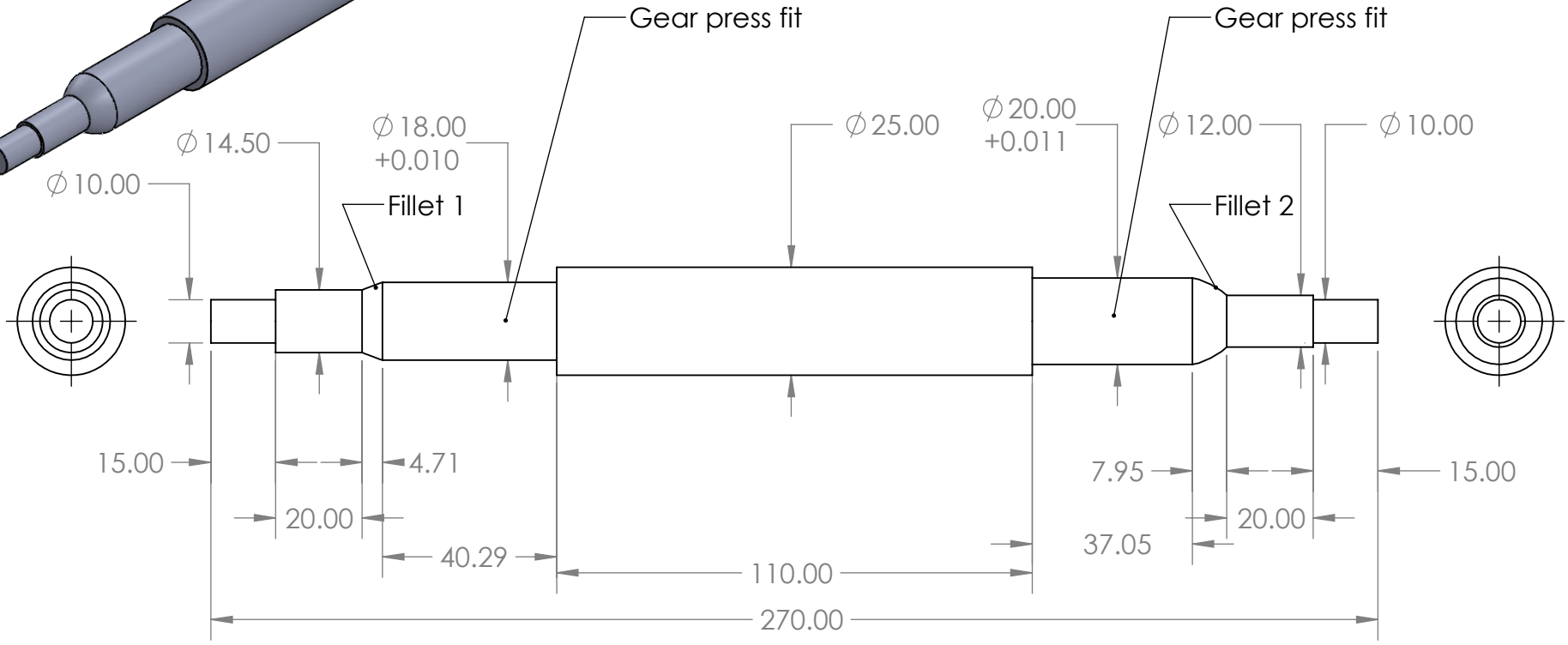

A

A

PROPRIETARY AND CONFIDENTIAL
 THE INFORMATION CONTAINED IN THIS DRAWING IS THE SOLE PROPERTY OF <INSERT COMPANY NAME HERE>. ANY REPRODUCTION IN PART OR AS A WHOLE WITHOUT THE WRITTEN PERMISSION OF <INSERT COMPANY NAME HERE> IS PROHIBITED.

		UNLESS OTHERWISE SPECIFIED:	NAME	DATE
		DIMENSIONS ARE IN MM	DRAWN	MD
		TOLERANCES:	CHECKED	4/30/20
		FRACTIONAL \pm	ENG APPR.	
		ANGULAR: MACH \pm BEND \pm	MFG APPR.	
		TWO PLACE DECIMAL \pm	Q.A.	
		THREE PLACE DECIMAL \pm	COMMENTS:	
		INTERPRET GEOMETRIC TOLERANCING PER:		
		MATERIAL		
		1566 Carbon Steel		
		FINISH		
		Smooth		
NEXT ASSY	USED ON			
APPLICATION		DO NOT SCALE DRAWING		

Dorantes Engineering		
TITLE:		
Intermediate Shaft		
SIZE	DWG. NO.	REV
A	FinalShaft	2
SCALE: 2:3	WEIGHT: 86.62g	SHEET 1 OF 1

2

1